

HYDRAULIC CYLINDERS



- └ Heavy Duty Hydraulic Cylinder
- └ Metric Design: ISO 6020/2, DIN 24554
- └ 210 Bar Working Pressure
- └ Hydraulic Cushioning Options
- └ Magnetic Versions
- └ Available in KITS

www.univer.co.uk

Index >>

VBM Series	Features / Technical Data	04
	Codification Key	05
	Mountings	06 - 07
	Special Modifications	08 - 09
	Port Locations / Special Thread Modifications	10
	Piston Rod Size Selection	11
	Standard Mounting Options	12 - 14
	Cylinder In Kits	15
	Cylinder Accessories	16 - 17
	Special Applications	18

VBM Series

Hydraulic Cylinder



Features

└ Robust Design

Manufactured and tested in the UK, VBM series cylinders are produced from the highest quality materials.

└ Available in KIT form

The product has been designed for quick and easy assembly, and is available in KITS for local Distributor production. Authorised cylinder production outlets are provided with extensive training and test equipment is controlled and audited by UMC technicians.

└ Quick Delivery

As the product has been designed for fast and easy assembly, delivery can be extremely quick. In addition special modifications can be carried out locally, such as special rod dimensions and mounting arrangements.

TECHNICAL DATA

	VBM	GVBM
Type	Standard	Magnetic
Operating Pressure (bar)	210	150
Pressure Safety Factor	4:1 at nominal pressure	
Bore (mm)	25 to 200 (GVBM 100 max)	
Stroke (mm)	up to 4000	
Operation Mode	Double acting	
Fluid	Hydraulic mineral oil - other fluids available upon request	
Ambient & Fluid Temperature (°C)	-20 to +80	
Dimensional Standard	In accordance with ISO 6020/2 (1991), DIN 24554 standards	
Construction	Tie rod design	
Piston Rod Diameters (mm)	12 to 140	
Cushions for Bore Sizes 25 & 32 (mm)	Non-adjustable cushioning	
Cushions for Bore Sizes 40 & 200 (mm)	Adjustable (either or both ends)	

Each UMC cylinder has a label with part number for easy identification.

Please always refer to cylinder part number when ordering spare parts and seal kits.

CODIFICATION KEY

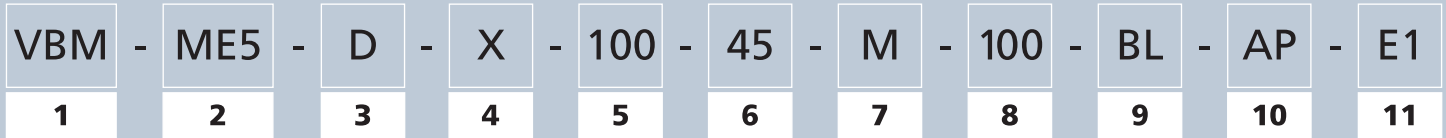

1 Series

- VBM** = Standard Cylinder - Non Magnetic
Ø 25 to 200 mm
- GVBM** = Magnetic Cylinder
Ø 25 to 100 mm only

2 Standard Mounting Options

- K** = No mounting option
- ME5** = Front end cap flange
- ME6** = Rear end cap flange*
- MP1** = Rear clevis (female)*
- MP3** = Rear clevis (male)*
- MP5** = Rear clevis (male) spherical bearing*
- MS2** = Foot mounting lugs
- MT1** = Front end cap trunnion
- MT2** = Rear end cap trunnion*
- MT4** = Centre trunnion
- MX1** = All tie rods extended
- MX2** = Rear end cap tie rods extended
- MX3** = Front end tie rods extended

*mounting not available on through rod cylinders

3 Through Rod Option

D = Through rod cylinder

4 Special Modifications

X = Please detail

5 Bore (mm) **6 Piston Rod Diameter (mm)**

25	12 or 18
32	14 or 22
40	18 or 28
50	22 or 36 (28*)
63	28 or 45 (36*)
80	36 or 56 (45*)
100	45 or 70 (56*)
125	56, 70 or 110 (90*)
200	90 or 140 (110*)

(*Additional rod diameters available which do not conform to ISO standards.)

7 Piston Rod Thread

- M** = Male (Standard)
- F** = Female (Standard)
- MY** = Male (Oversized thread)
- FY** = Female (Oversized thread)

8 Stroke

Specify in mm

9 Seals

- | | Piston | Rod |
|---|--------|---------------------------------|
| BL = Low-friction nitrile (standard) | | Low-friction nitrile (standard) |
| BV = Low-friction viton | | Low-friction viton |

10 Cushionings

- N** = Non-cushioned
- A** = Head end cushioning
- P** = Cap end cushioning
- AP** = Both ends cushioned

11 Serial Number

E1 = To be always included

AVAILABLE MOUNTINGS

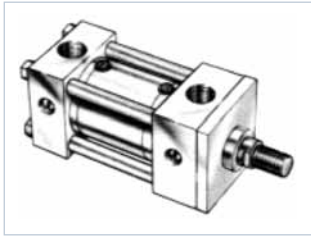
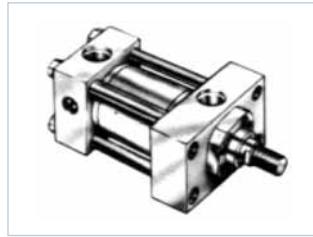
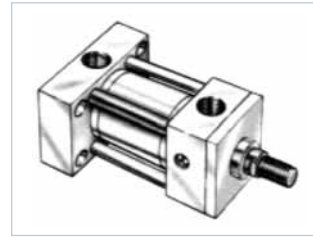
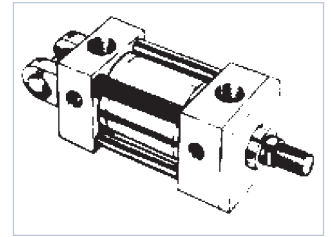
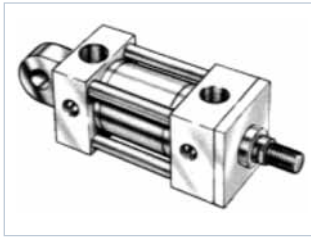
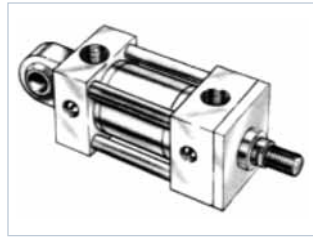
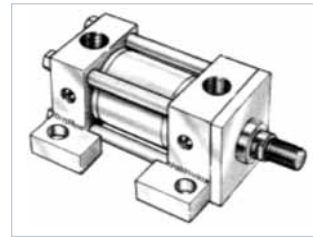
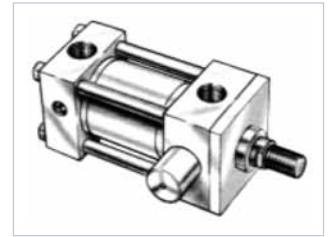
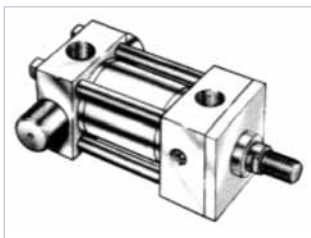
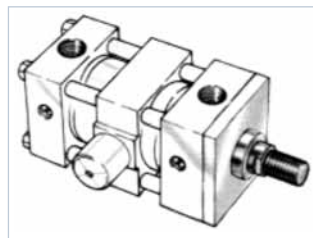
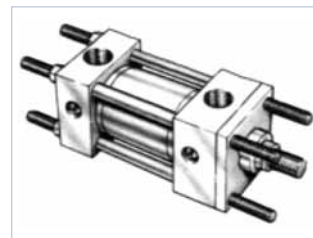
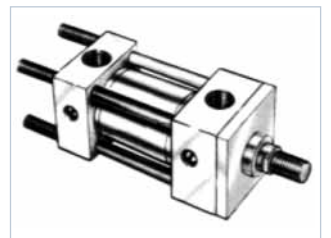
 No mounting option
VBM-K - VBM-KD

 Front end cap flange
VBM-ME5 - VBM-ME5D

 Rear end cap flange
VBM-ME6

 Rear clevis (female)
VBM-MP1

 Rear clevis (male)
VBM-MP3

 Rear clevis (male)
with spherical bearing
VBM-MP5

 Foot mounting lugs
VBM-MS2-MS2D

 Front end cap trunnion
VBM-MT1 - VBM-MT1D

 Rear end cap trunnion
VBM-MT2

 Centre trunnion
VBM-MT4 - VBM-MT4D

 All tie rods extended
VBM-MX1 - VBM-MX1D

 Rear end cap tie
rods extended
VBM-MX2

MOUNTING INFORMATION

Extended tie rod mountings

Mounting suitable for use with lateral forces and applications where mounting space is limited. For compression-type applications (forward thrust), Rear End Caps with extended rear tie rods (type MX2) are recommended. Use Front End Caps with extended tie rods (type MX3) for applications involving tension (pulling force).

Flange mounted cylinders

Mounting suitable for use in straight line force transfer applications. Two mounting styles are available: 1: Front End Cap flange (type ME5) or Rear End Cap flange (type ME6). Flange type ME6 is more appropriate for compression-type applications (forward thrust). Flange type ME5 must be used when high load places the piston rod in tension (pulling force).

Clevis mounted cylinders

Cylinders with Clevis mounting should be used for applications where a curved movement path is required. This type of mounting is suitable for tension (pull) or compression (push) applications. Fixed cap clevis mounting cylinders (types MP1 & MP3) should only be used if the curved path of the piston rod travels in one plane. For applications where the piston rod will travel in a path either side of the direct plane of motion, Rear Clevis mountings with Spherical Bearing (type MP5) must be used.

Foot mounted cylinders

Cylinders with Foot Mounting Lugs (type MS2) do not absorb force on their centre-lines. As a result, the resultant forces produced by the cylinder/application create a bending moment which attempts to rotate the cylinder about its mounting bolts. It is therefore important for the cylinder to be firmly secured to the machine and for the load to be effectively guided.

Trunnion mounted cylinders

Cylinders with differing Trunnion Mountings (types MT1, MT2 & MT4) are designed to absorb force on their centre-lines, and are therefore suitable for tension (pull) or compression (push) applications. Trunnion Mounted cylinders may be used where a mechanism needs to travel in a curved path, in a single plane. Trunnion pins are designed for shear loads only, and should be subject to minimum bending stresses.

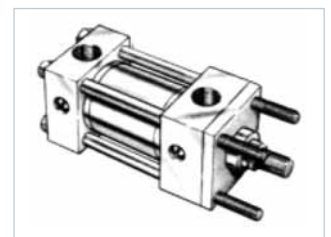
 Front end tie rods extended
VBM-MX3 - VBM-MX3D

1 Rod cartridge

The VBM series Cartridge is precision machined from steel and houses scraper & rod seals and a bronze guide bearing, which provides maximum bearing support and wear resistance within the controlled ISO dimensions. Cartridge removal is easy, using standard metric hex wrenches without loosening the tie rods.

2 Rod seals

Standard rod seals are made from polyurethane, and provide long life together with high wear resistance. A heavy duty double-lipped rod wiper removes contamination from the exposed rod to extend seal life. Standard rod seal temperature range is -20° +80°. Various seal materials are available upon request including Viton for high temperature applications (up to 150°). Low friction seals as standard.

3 Piston rod

The piston rod is manufactured from high tensile carbon alloy C45 steel, hard chrome plated and polished (0,025 mm) to maximum surface finish of 0,2 µm (tolerance f7).

4 Piston and piston seals

The standard Piston is a one-piece steel construction, and is matched to the rod for concentricity. The standard piston seal consists of an elastomeric sealing element, wear rings (x2), and heavy duty anti-friction rings (x2). The standard piston seal is not suitable for prolonged load holding duties so it is essential to adequately support the load. Temperature range of standard piston seal is -20° +80°. Low friction seals as standard. Viton seals are available upon request.

5 Ports

VBM series cylinders are supplied as standard with BSPP ports. Other ports are also available upon request.

6 Head & cap ends

Assembly screws are machined from steel and designed to be precisely aligned when located into the End Caps, providing added strength and precise tube concentricity.

7 Cylinder barrel

The Barrel is made from high resistance steel, honed to a precision finish (0,4 Ra). The machined barrel end faces are designed to ensure a positive O-ring seal between Barrel and cylinder End Caps even under the most arduous conditions.

8 Cushioning

UMC's patented end of stroke cushioning is available for either or both End Caps. Hydraulic cushioning provides controlled deceleration, reducing noise, shock load and prolonging machine life.

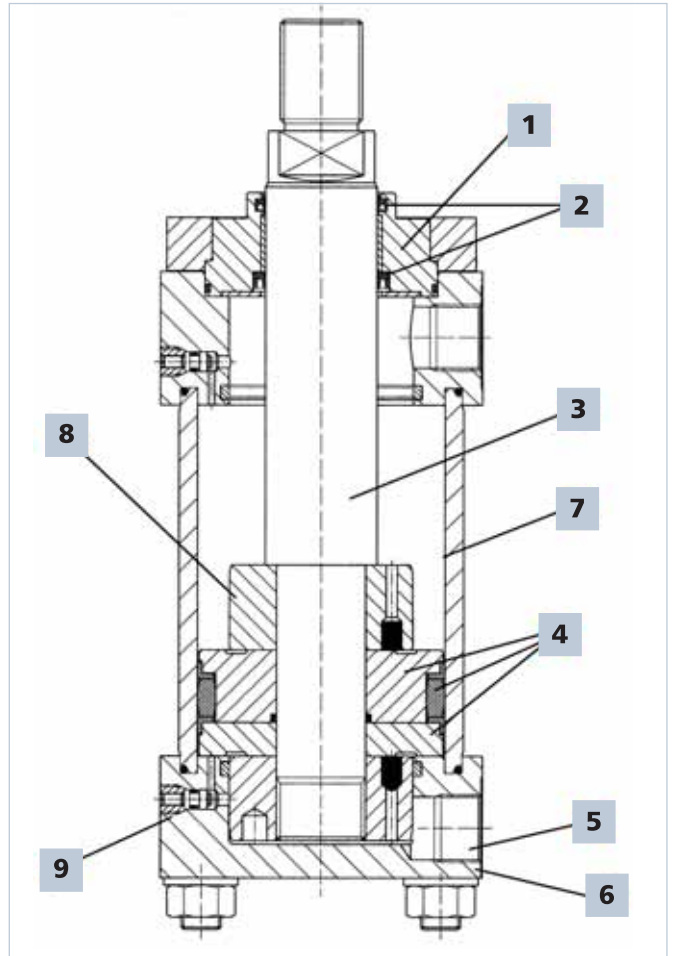

9 Cushion adjustment screw

Cushion adjustment screws provide precision speed control adjustment. The screws are securely retained and cannot be unintentionally ejected. Cushion screws are profiled for fine adjustment. Adjustable cushioning option is not available for bore sizes 25 & 32mm (only non-adjustable).

Long strokes

For applications requiring cylinders with long stroke lengths (more than 1000 mm) Stop Tubes should be used to reduce piston and cartridge wear.

Refer to table below for recommended stop tube lengths:

Stroke (mm)	1001 ÷ 1500	1501 ÷ 2000	2001 ÷ 2500	2501 ÷ 3000
Stop tube length (mm)	50	100	150	200

Note: For long stroke cylinders above 1000 mm End Caps should be attached to heavy duty steel flanges. For further information contact our Technical Office.

SPECIAL MODIFICATIONS

Air bleeds

Air Bleed ports are available as an option as shown positioned below. Non-standard position locations are also available upon request but must be specified when placing your order.

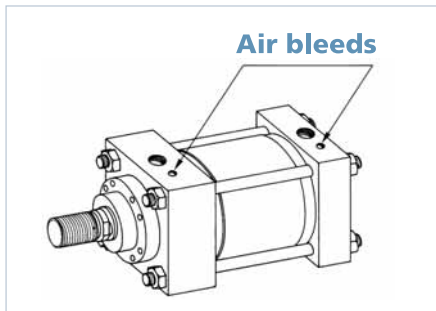
**Rod end bellow**

A rod end bellow is recommended to protect the rod surface from external contamination and abrasive dust. Additional rod length is required to accommodate the collapsed length of the bellows. For further information please contact our Technical Department.

Drainback

A 1/8 BSP drainback port can be provided to drain off accumulation of fluid. This can happen on long stroke cylinders, cylinders with constant back pressure and cylinders with in/out speed rating differing by more than 2:1.

MT4 mounting

XV dimension must be included between XV (min) and XV (max) + stroke, and must always be specified when ordering a cylinder. If the required cylinder stroke is less than the minimum XV dimension outlined in the chart, spacers will be required (please consider added dimensions for overall cylinder length).

Stroke tolerance

We recommend choosing a longer stroke cylinder than the effective stroke required to avoid the piston acting as a mechanical stop.

Stroke length tolerances must also be considered due to the build-up of component tolerances (piston, end caps and barrel):

± 1 mm	0 ÷ 499
± 1,5 mm	500 ÷ 1249
± 2,5 mm	1250 ÷ 3149
± 4,5 mm	3150 ÷ 8000

Linear transducer

A special end cap is available which allows Linear Position Transducers to be fitted to VBM series cylinders. Please contact our Technical Department for further details.

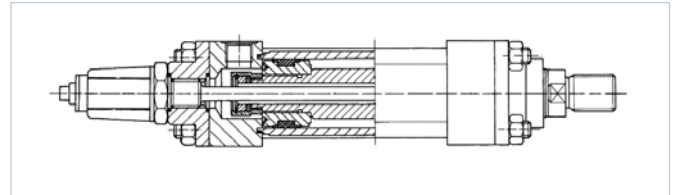
**Proximity sensors**

Proximity Sensors are available for VBM series cylinders and can be factory fitted on either or both end caps. Please contact our Technical Department for further details.

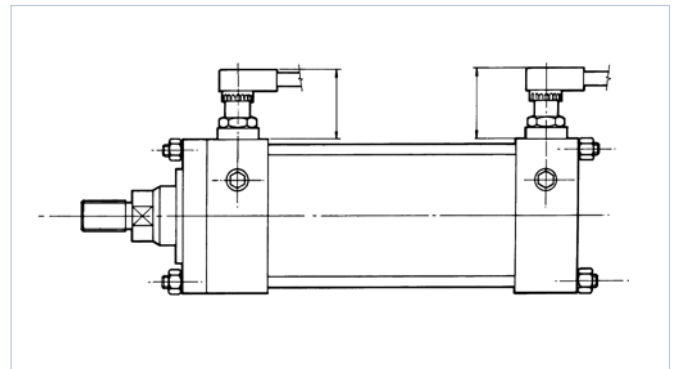
**Tandem cylinders**

Tandem cylinders consist of two pistons interconnected in one cylinder to provide two effective piston areas allowing the cylinder to exert twice the force (cylinders must have the same stroke).

For further information please contact our Technical Department.

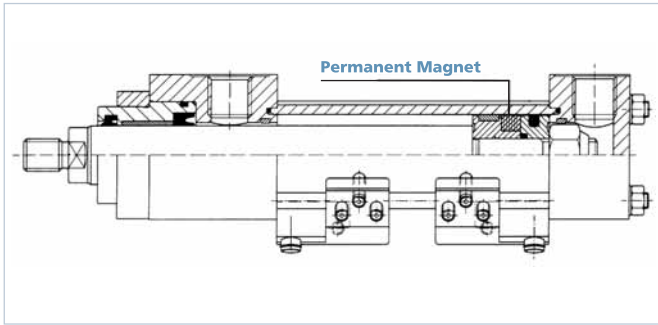

Cylinder specifications

Cylinders manufactured in accordance with ISO 6020/2 standard. Max. working pressure 150 bar.

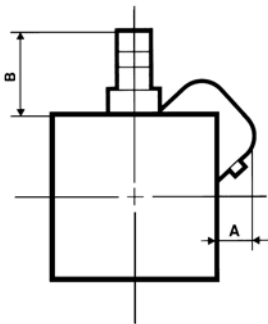

Bore Ø	A mm	B mm
32/40	16	27
50/100	18	27

Solid State Switch (PNP) instructions for use

Solid state PNP switches are available on all bore sizes and are firmly attached to the tie rod and held in position by an aluminium bracket. The bracket is designed so as to eliminate the possibility of the switch being pulled out of position. Switches are activated by a permanent magnetic band fitted around the internal piston and must always be used with a load (inductive, capacitive or resistive). When used in sequence each switch has a voltage drop of 3V. Minimising cable dimensions to the shortest possible length will avoid electrical damage to the switch. For cables longer than 10 metres, we recommend fitting an inductor in order to nullify the effect of cable capacity.

Technical Data - PNP Switches

Electric data	Normally open contact
Voltage	IP 65 protection
Current at 25°	6-30 Volt
Max power	250 mAmp
Switch on time	6 Watt
Switch off time	0,8 micro sec
Switch on point	0,3 micro sec
Switch off point	30 Gauss
Electric life	25 Gauss
Voltage drop	109 pulses
Temperature	0,7 Volt
Detection speed	-20°C +85°C
	1m/sec (max)

OVERSIZED PORTS

Bore Ø	Standard Ports	Oversized Ports
25	G 1/4"	G 3/8"
32	G 1/4"	G 3/8"
40	G 3/8"	G 1/2"
50	G 1/2"	G 3/4"
63	G 1/2"	G 3/4"
80	G 3/4"	G 1"
100	G 3/4"	G 1"
125	G 1"	G 1. 1/4"
160	G 1"	G 1. 1/4"
200	G 1. 1/4"	G 1. 1/2"

Oversize ports, non-standard port threads and cushioning screw locations are available upon special request as such modifications are considered non-standard.

PORT LOCATIONS

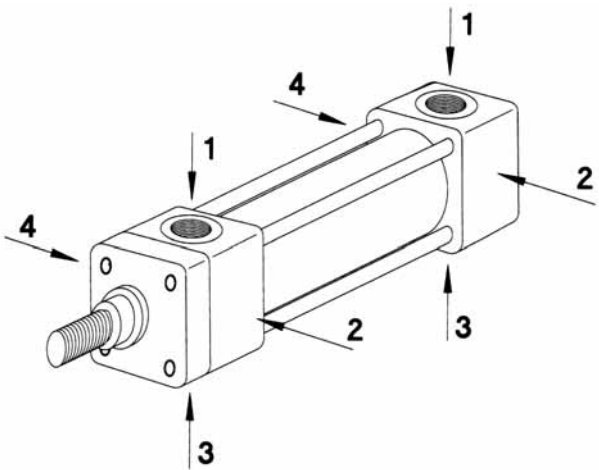

1 = Standard Port Location

2 = Standard Cushion Screw Location

1, 2, 3 & 4 = Optional Port & Cushion Screw Locations
(Upon request)

To order non-standard port and cushion adjustment screw locations please specify by using position numbers from the drawing above.

Cushion adjustment screws are not available on bore size 25 and 32. Cushioning can only be non-adjustable on these bore sizes.

SPECIAL THREAD MODIFICATIONS

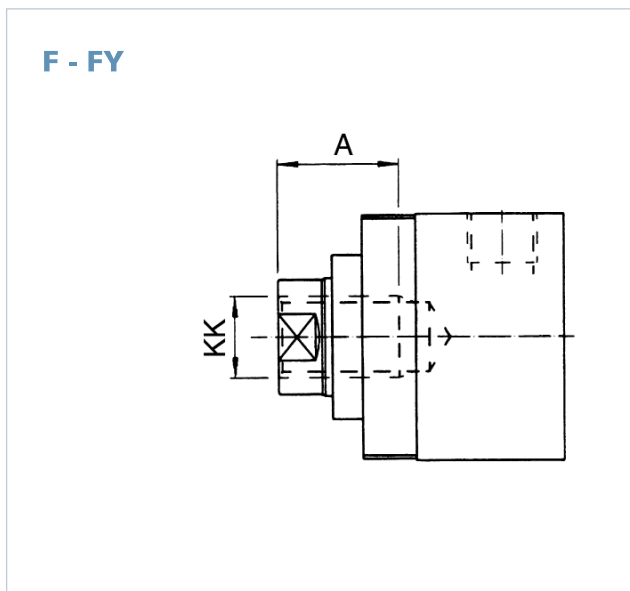
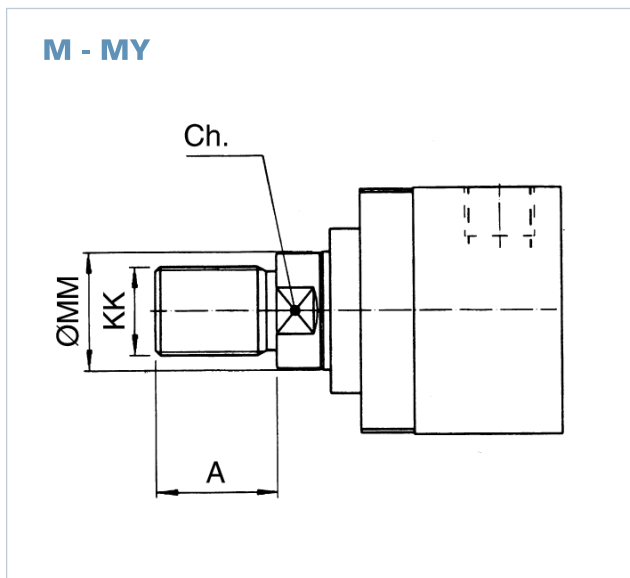

Bore	Rod (mm)	Standard Threads Type M - F		Oversized Threads Type MY- FY		Ch
		KK	A	KK	A	
25	12	M10x1.25*	14			10
	18	M10x1.25	14	M14x1.5*	18	15
32	14	M12x1.25*	16			12
	22	M12x1.25	16	M6x1.5	22	19
40	18	M14x1.5*	18			15
	28*	M14x1.5	18	M20x1.5	28	24
50	22	M16x1.5	22			19
	28	M20x1.5	28			24
63	36*	M16x1.5	22	M27x2	36	32
	28	M20x1.5	28			24
80	36	M27x2	36			32
	45*	M20x1.5	28	M33x2	45	40
100	36	M27x2	36			32
	45	M33x2	45			40
125	56*	M27x2	36	M42x2	56	50
	45	M33x2	45			40
160	56	M42x2	56			50
	70*	M33x2	45	M48x2	63	60
200	56	M42x2	56			50
	70	M48x2	63			60
250	90*	M64x3	85	M64x3	85	80
	110	M48x2	63	M80x3	95	100
320	70	M48x2	63			60
	90*	M64x3	85			80
400	110	M48x2	63	M80x3	95	100
	90	M64x3	85			80
500	110*	M80x3	95			100
	140	M64x3	85	M100x3	112	130

(*Additional rod diameters available which do not conform to ISO standards.)

For any further information please contact our Technical Department.

PISTON ROD SIZE SELECTION

To select a piston rod based on thrust conditions requires the following steps to be carried out:

Step 1: Determine the type of cylinder mounting to be used (refer to fig.1) and obtain stroke length (D in mm). Determine (L) using the formulas indicated below. Should (L) dimension be over 1000 mm please refer to 'Long strokes' instructions on page 7.

Step 2: Find the load imposed for the thrust application as follows: (Fp in N) = full bore area (in cm²) x system pressure (in bar). Use the piston rod load chart to calculate thrust using values L and Fp (refer to fig. 2). Draw the coordinates and note the point of intersection. The correct piston rod size is read from the diagonally curved line above the point of intersection.

Example: L=6500 mm Fp = 10.000 N the most suitable rod size is 70 mm (refer to fig. 2)

CYLINDER MOUNTING ROD SELECTION GUIDE

Fig. 1

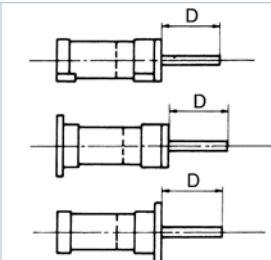
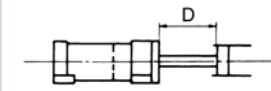
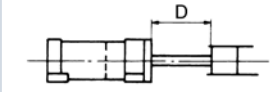
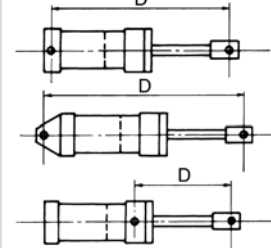
Unsupported rod end		$L = D \times 4$
Supported rod end		$L = D$
Firmly guided rod end		$L = \frac{D}{2}$
Pivoted firmly guided rod end		$L = D$

PISTON ROD LOAD CHART

Example:

L=6500 mm Fp = 10.000 N the most suitable rod size is 70 mm

Fig. 2

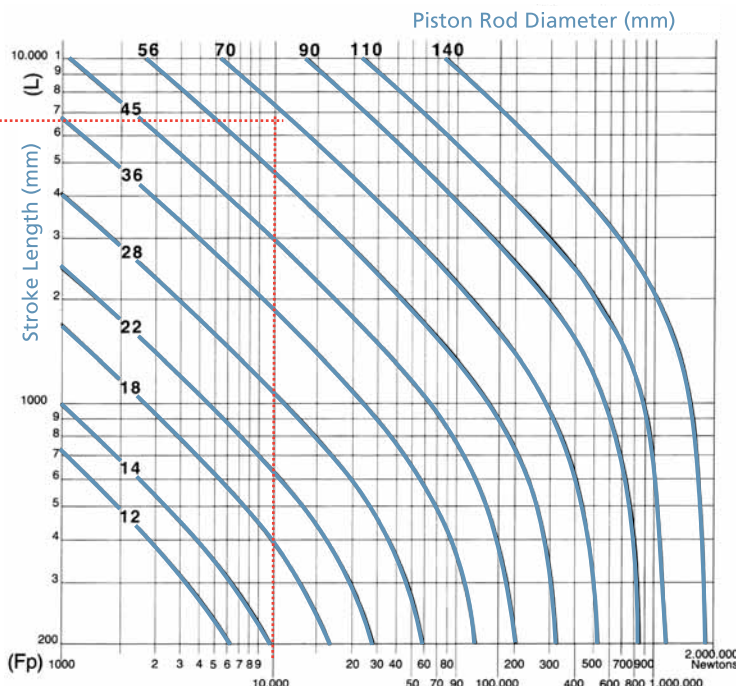

No Mount K

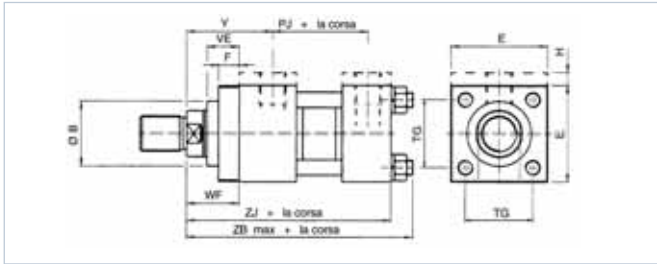

Head rectangle flange - ME5



Cap rectangular flange - ME6

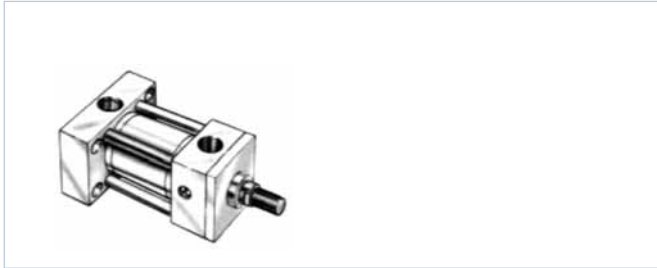

Cap fixed clevis - MP1

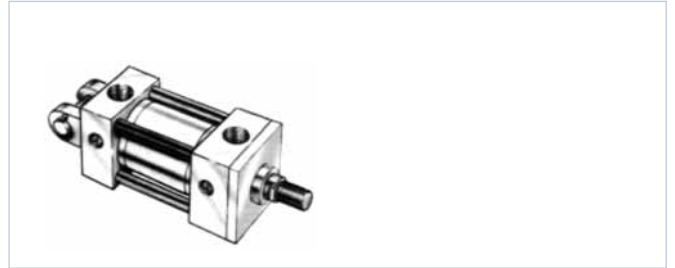

Cap eye - MP3

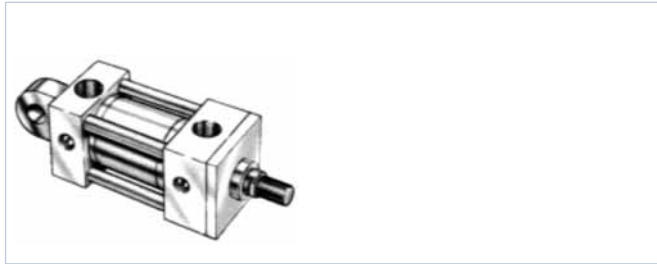

Side lugs - MS2

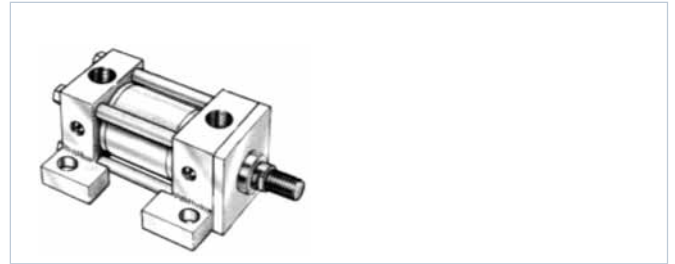

Cap spherical bearing MP5

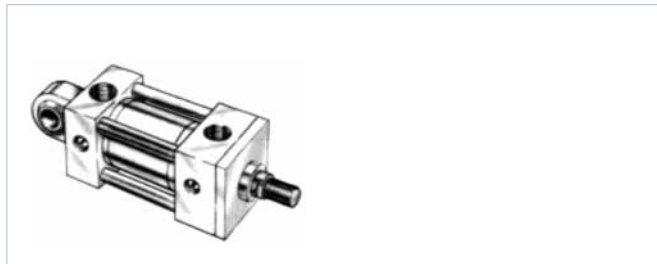

Head trunnion - MT1

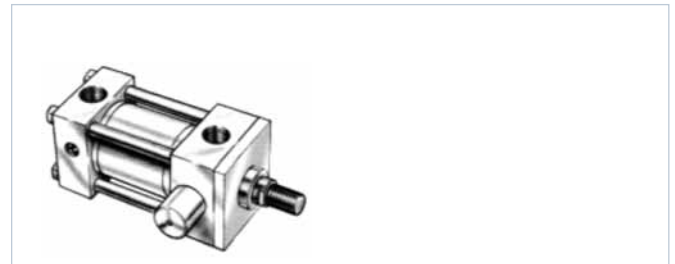

Cap trunnion - MT2

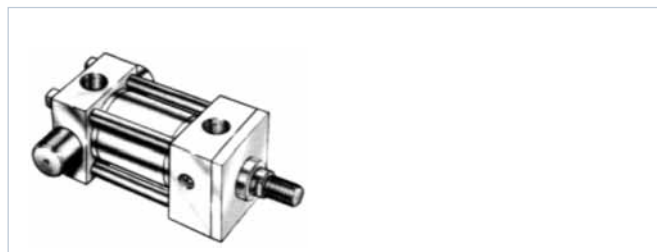

Intermediate fixed trunnion - MT4

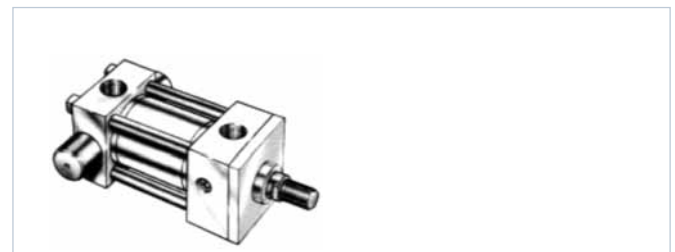

Head end tie rods extended - MX3

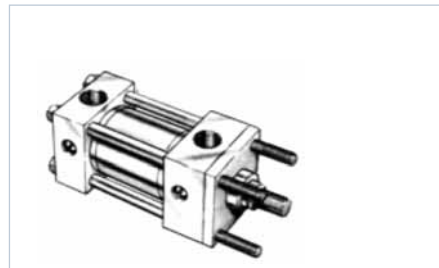

Cap end tie rods extended - MX2

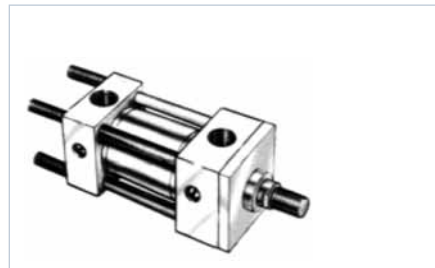

All tie rods extended - MX-1

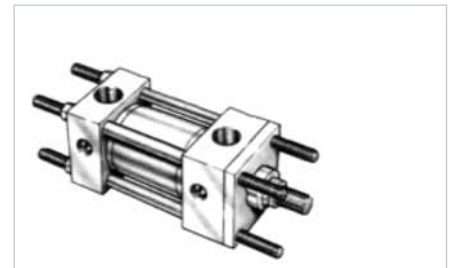

Hydraulic Cylinder ISO 6020/2

VBM Series

Bore	Ø Rod	B	BB	CB A16	CD Toll.	CX	DD	E	EP	EW h14	EX	F	FB	G	H	L	LH h10	LT	MR	MS	PJ	R	RD f8	SB	SS
25	12	24	19	12	10	12 ⁰ _{-0.008}	M5x0.8	40	8	12	10	10	5.5	25	5	18	19	16	12	22	53	27	38	6.6	73
	18	30																							
32	14	26	24	16	12	16 ⁰ _{-0.008}	M6x1	45	11	16	14	10	6.6	25	5	19	22	20	17	22.5	56	33	42	9	73
	22	34																							
40	18	30	35	20	14	20 ⁰ _{-0.012}	M8x1	63	13	20	16	10	11	38		19	31	25	17	29	73	41	62	11	98
	28	42																							
50	22	34	30	30	20	25 ⁰ _{-0.012}	M12x1.25	75	17	30	20	16	14	38		32	37	31	29	33	74	52	74	14	92
	36	50																							
	28	42																							
63	28	42	30	30	20	30 ⁰ _{-0.012}	M12x1.25	90	19	30	22	16	14	38		32	44	38	29	40	80	65	75	18	86
	45	60																					88		
	36	50																					88		
80	36	50	40	40	28	40 ⁰ _{-0.012}	M16x1.5	115	23	40	28	20	18	45		39	57	48	34	50	93	83	82	18	105
	56	72																					105		
	45	60																					105		
100	45	60	50	50	36	50 ⁰ _{-0.012}	M16x1.5	130	30	50	35	22	18	45		54	63	58	50	62	101	97	92	26	102
	70	88																					125		
	56	72																					125		
125	55	72	60	60	45	60 ⁰ _{-0.015}	M22x1.5	165	38	60	44	22	22	58		57	82	72	53	80	117	126	105	26	131
	90	108																					150		
	70	88																					150		
160	70	88	70	70	56	80 ⁰ _{-0.015}	M27x2	205	47	70	55	25	26	58		63	101	92	59	100	130	155	125	33	130
	110	133																					170		
	90	108																					170		
200	90	108	80	80	70	100 ⁰ _{-0.015}	M30x2	245	57	80	70	25	33	76		82	122	116	82	120	165	190	150	39	172
	140	163																					210		
	110	133																					210		

Bore	Ø Rod	ST	TC	TD f8	TG	TM	TO	TS	UB	UM	UO	US	UT	UW	VD □	VE	WF	WH	XC	XG	XJ	XO	XS	XV min	XV max	Y	ZB	ZJ	min. stroke for mounting MT4
25	12	8.5	38	12	28.3	48	51	54	24	68	65	72	58	48	6	16	25	15	127	44	101	130	83	82	72	50	121	114	10
	18																							+stroke					
32	14	12.5	44	16	33.2	55	58	63	32	79	70	84	68	55	12	22	35	25	147	54	115	148	45	96	82	60	137	128	14
	22																							+stroke					
40	18	12.5	63	20	41.7	76	87	83	40	108	110	103	85	76	12	22	35	25	172	57	134	178	45	107	88	62	166	153	19
	28																							+stroke					
50	22	19	76	25	52.3	89	105	102	60	129	130	127	116	89	9	25	41	25	191	64	140	190	54	117	90	67	178	158	27
	36																							+stroke					
	28																												
63	28	26	89	32	64.3	100	117	124	60	150	145	161	139	100	13	28	48	32	200	70	149	206	65	132	91	71	185	168	41
	45																							+stroke					
	36																												
80	36	26	114	40	82.7	127	149	149	80	181	180	186	178	127	9	29	51	31	220	76	168	238	68	147	99	77	212	190	48
	56																							+stroke					
	45																												
100	45	32	127	50	96.9	140	162	172	100	220	200	216	207	140	10	32	57	35	257	71	187	261	78	158	107	82	225	203	51
	70																							+stroke					
	56																												
125	55	32	165	63	125.9	178	208	210	120	278	250	254	265	178	10	32	57	35	288	75	208	304	79	180	109	86	260	232	71
	90																							+stroke					
	70																												
160	70	38	203	80	154.9	215	253	260	140	341	300	318	329	215	7	32	57	32	308	75	280	337	86	198	104	86	279	245	94
	110																							+stroke					
	90																												
200	90	44	241	100	190.2	278	300	311	160	439	360	381	401	279	7	32	57	32	381	85	276	415	92	226	130	98	336	299	96
	140																							+stroke					
	110																												

See above chart for minimum stroke for MT4 mounting.

XV dimension is always to be specified when ordering a cylinder with MT4 mounting. The value must be between minimum XV and maximum XV + stroke

All tie rods extended - MX1D

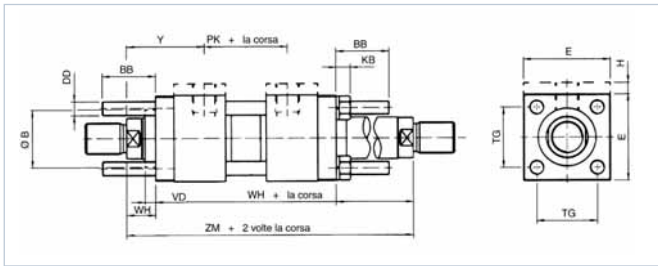

Head rectangular flange - ME5D

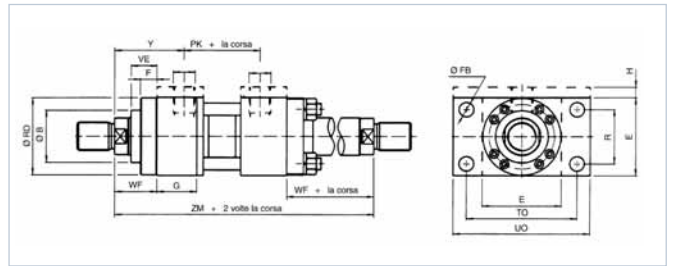

Head trunnion - MT1D

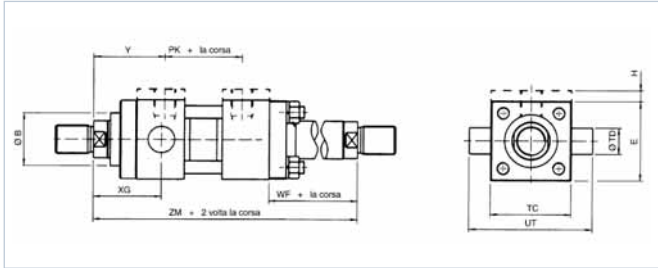

Intermediate fixed trunnion - MT4D

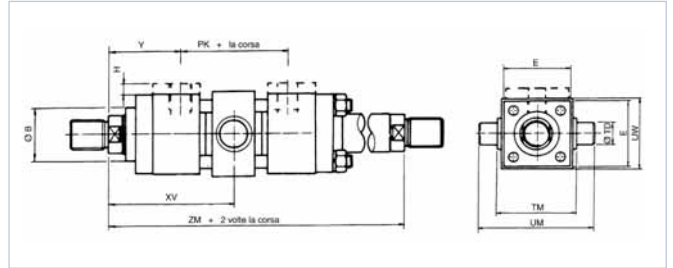

Side lugs - MS2D

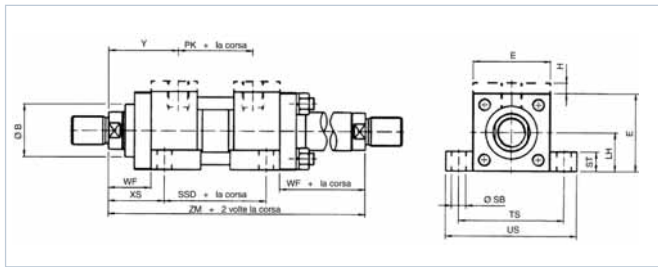

Head end tie rods extended - MX3D

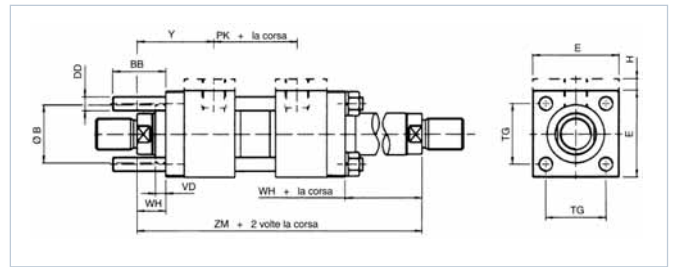

Bore Ø Rod	B	BB	DD	E	F	FB	G	H	KB	LH h10	PK	R	RD f8	SB	SSD	ST	TC	TD f8	TG	TM	TO	TS	UM	UO	US	UT	UW	VD	VE	WF	WH	XG	XS	XV min	XV max	Y	ZM	min. stroke for mounting MT4							
25	12	24	19	M5x0,8	40	10	5.5	25	5	5.2	19	54	27	38	6.6	88	8.5	38	12	28.3	48	51	54	68	65	72	58	48	6	16	25	15	44	33	82	72	50	154	10						
	18	30																																											
32	14	26	24	M6x1	45	10	6.6	25	5	6.6	22	58	33	42	9	88	12.5	44	16	33.2	55	58	63	79	70	84	68	55	12	22	35	25	54	45	96	82	60	178	14						
	22	34																																											
40	18	30	35	M8x1	63	10	11	38		8.5	31	71	41	62	11	105	12.5	63	20	41.7	76	87	83	108	110	103	95	76	12	22	35	25	57	45	107	88	62	195	19						
	28	42																																											
50	22	34	46	M12x1.25	75	16	14	38		12.5	37	73	52	74	14	99	19	76	25	52.3	89	105	102	129	130	127	116	89	9	25	41	25	64	54	117	90	67	207	27						
	36	50																																											
	28	42																																											
63	28	42	46	M12x1.25	90	16	14	38		12.5	44	81	65	75	18	93	26	89	32	64.3	100	117	124	150	145	161	139	100	13	29	48	32	70	65	132	91	71	223	41						
	45	60																																											
	36	50																																											
80	36	50	59	M16x1.5	115	20	18	45		16.5	57	92	83	82	18	110	26	114	40	82.7	127	149	149	191	180	186	178	127	9	29	51	31	76	68	147	99	77	246	48						
	56	72																																											
	45	60																																											
100	45	60	59	M16x1.5	130	22	18	45		16.5	63	101	97	92	26	107	32	127	50	69.9	140	162	172	220	200	216	207	140	10	32	57	35	71	79	158	107	82	265	51						
	70	88																																											
	56	72																																											
125	55	72	81	M22x1.5	165	22	22	58		22	82	117	126	105	26	131	32	165	63	125.9	178	208	210	278	250	254	265	178	10	32	57	35	75	79	180	109	86	289	71						
	90	108																																											
	70	88																																											
160	70	88	92	M27x2	205	25	26	58		27	101	130	155	125	33	130	38	203	80	154.9	215	253	260	341	300	318	329	215	7	32	57	32	75	86	198	104	86	302	84						
	110	133																																											
	90	108																																											
200	90	108	115	M30x2	245	25	33	76		30	122	160	190	150	39	172	44	241	100	190.2	279	300	311	439	360	381	401	279	7	32	57	32	85	92	226	130	98	356	96						
	140	163																																											
	110	133																																											

See above chart for minimum stroke for MT4 mounting.

XV dimension is always to be specified when ordering a cylinder with MT4 mounting. The value must be between minimum XV and maximum XV + stroke

CYLINDER KITS

VBM Series Hydraulic Cylinders are available in kits with assembly instructions provided to allow this range to be assembled by authorised UMC distributors and approved OEM clients. Kits can be supplied without tube, piston and tie rods, alternatively these items can be supplied by UMC. For further information please contact us.



CYLINDER KIT COMPONENTS

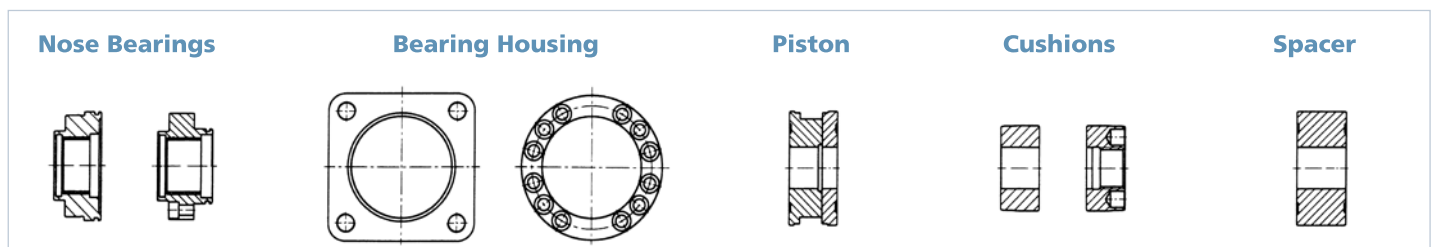
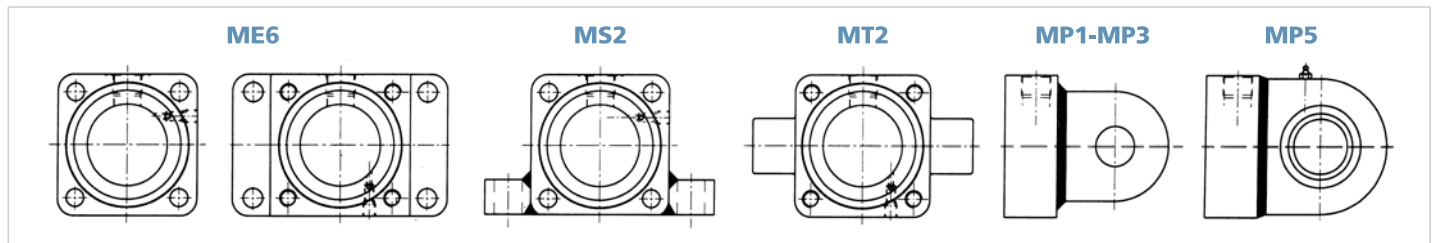
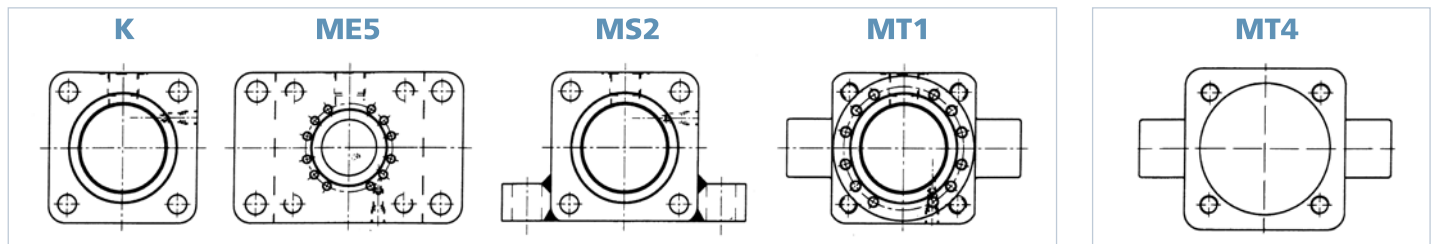

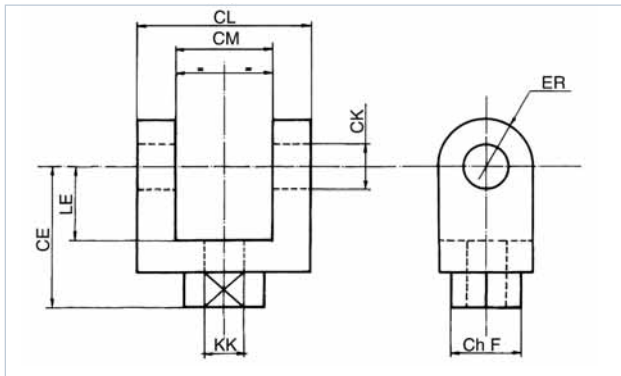
CYLINDER ACCESSORIES
Femal clevis ISO 6982 (pivot pin not included)

Part number	CM	CKH9	CE	CL	ChF	KK	LE	ER
258CF-H-10	12	10	32	26	19	10x1,25	13	12
258CF-H-12	16	12	36	34	21	12x1,25	19	17
258CF-H-14	20	14	38	42	21	14x1,5	19	17
258CF-H-16	30	20	54	62	32	16x1,5	32	29
258CF-H-20	30	20	60	62	32	20x1,5	32	29
258CF-H-27	40	28	75	83	40	27x2	39	34
258CF-H-33	50	36	99	103	56	33x2	54	50
258CF-H-42	60	45	113	123	56	42x2	57	53
258CF-H-48	70	56	126	143	75	48x2	63	59
258CF-H-64	80	70	168	163	95	64x3	83	78
258CF-H-80	80	70	168	163	95	80x3	83	78
258CF-H-100	100	100	250	230	160	100x3	90	95

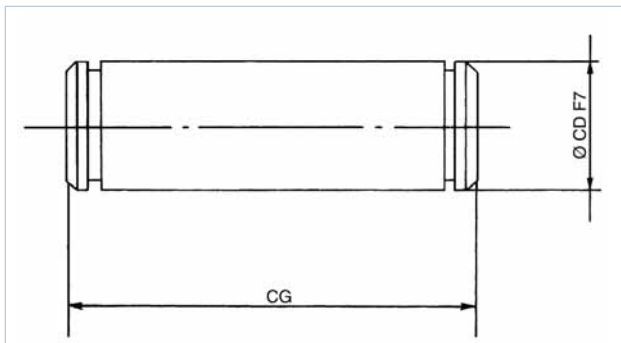
Pivot pin

Part number	CD	CG
2.44.01.37.95	10	32
2.44.05.37.95	12	40
2.44.10.37.95	14	50
2.44.15.37.95	20	70
2.44.25.37.95	28	92
2.44.30.37.95	36	114
2.44.35.37.95	45	135
2.44.40.37.95	56	158
2.44.45.37.95	70	180

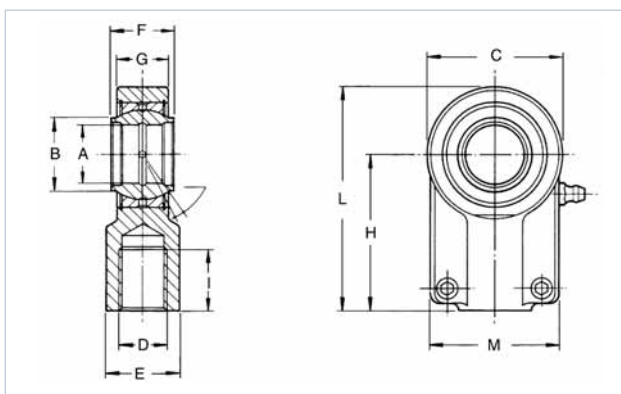
Spherical rod eye ISO 6982

Type TAPR	A h7	B	C	D	E	F h12	G	H	I	L	M	Stat. Load	Din. Load
290GIHnk10LO	10	12,5	32	M10x1,25	15	10	7	37	14	53	32	20	8,15
290GIHnk12LO	12	15,5	32	M12x1,25	16	12	10,5	38	17	54	32	24,5	10,8
290GIHnk16LO	16	20	40	M14x1,5	21	16	13	44	19	64	40	36,5	17,8
290GIHnk20LO	20	25	47	M16x1,5	25	20	17	52	23	77	47	48	30
290GIHnk25LO	25	30,5	58	M20x1,5	30	25	21	65	29	96	54	78	48
290GIHnk32LO	32	38	70	M27x2	38	32	27	80	37	118	66	114	67
290GIHnk40LO	40	46	89	M33x2	47	40	32	97	46	145,5	80	114	67
290GIHnk50LO	50	57	108	M42x2	58	50	40	120	57	179	96	310	156
290GIHnk63LO	63	71,5	132	M48x2	70	63	52	140	64	211	114	430	255
290GIHnk80LO	80	91	168	M64x3	90	80	66	180	86	270	148	695	400
290GIHnk100LO	100	113	210	M80x3	110	100	84	210	96	322	178	1060	610
290GIHnk125LO	125	138	264	M100x3	135	125	102	260	113	405	200	3650	2120

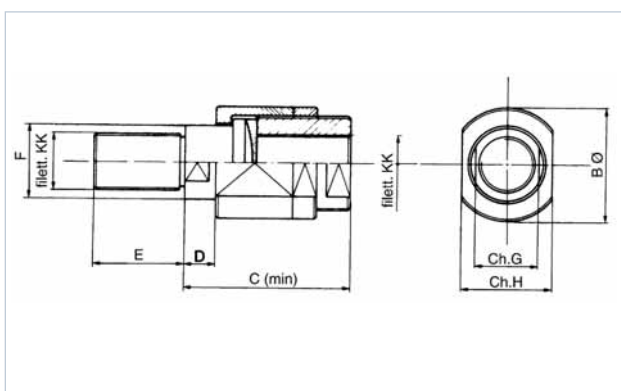
Self-aligning rod end coupler

Part Number	B	C	D	E	F	G	H	KK
AUT-H-10125	31,7	50,8	12,7	19	15,9	14	20	10x1,25
AUT-H-12125	31,7	50,8	12,7	19	15,9	14	20	12x1,25
AUT-H-1415	42,8	58,7	12,7	28,5	24,6	22	28	14x1,5
AUT-H-1615	42,8	58,7	12,7	28,5	24,6	22	28	16x1,5
AUT-H-2015	42,8	58,7	12,7	28,5	24,6	22	28	20x1,5
AUT-H-272	57	73,8	12,7	41	34,1	30	42	27x2
AUT-332	66,6	91,8	19	51	43,6	38	50	33x2
AUT-H-422	76,2	105,5	22,2	57	50	44	60	42x2
AUT-482	95,2	138,1	25,4	76	62,7	54	76	48x2
AUT-H-643	127	163,5	25,4	89	88,1	76	102	64x3
AUT-H-803	184	238,1	25,4	140	138,9	*	146	80x3
AUT-H-1003	184	238,1	25,4	140	138,9	*	146	100x3

CYLINDER ACCESSORIES

Eye Bracket

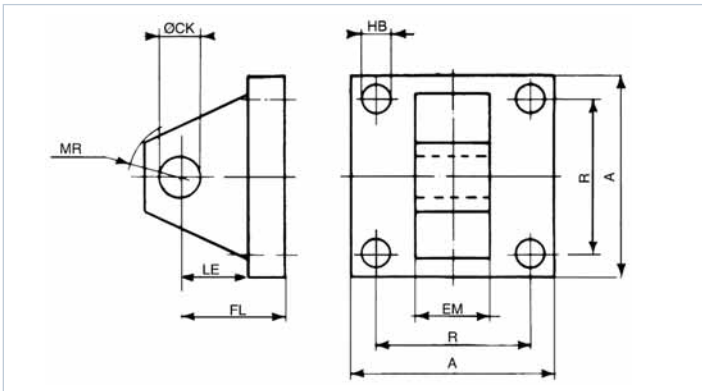

Part Number	A	R	EMh13	HB	CKH9	MRmax	LEmin	FL
CCM-H-10	40	28,3	12	5,5	10	12	13	23
CCM-H-12	45	33,2	16	6,6	12	17	19	29
CCM-H-14	65	41,7	20	9	14	17	19	29
CCM-H-20	75	52,3	30	13,5	20	29	32	48
CCM-H-20-A	90	64,3	30	13,5	20	29	32	48
CCM-H-28	115	82,7	40	17,5	28	34	39	59
CCM-H-36	130	96,9	50	17,5	36	50	54	79
CCM-H-45	165	125,9	60	26	45	53	57	87
CCM-H-56	205	154,9	70	30	56	59	63	103
CCM-H-70	240	190,2	80	33	70	78	82	132

Female Eye

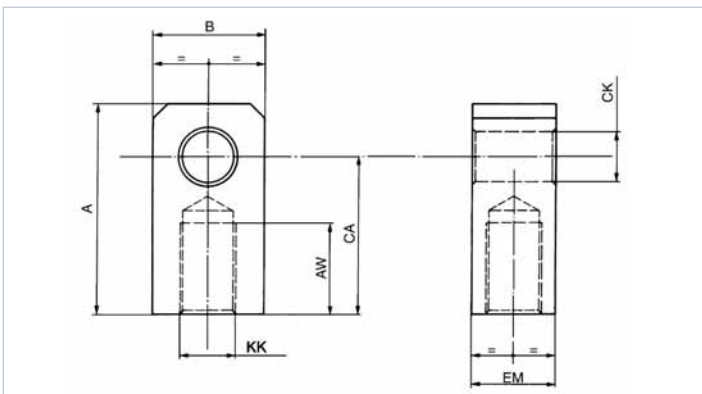

Part Number	A	B	EM	CKH9	CA	AW	KK
CM-H-10125	44	20	12	10	32	14	10x1,25
CM-H-12125	53	24	16	12	36	16	12x1,25
CM-H-1415	55	28	20	14	38	18	14x1,5
CM-H-1615	83	40	30	20	54	22	16x1,5
CM-H-2015	89	40	30	20	60	28	20x1,5
CM-H-272	109	56	40	28	75	36	27x2
CM-H-332	149	72	50	36	99	45	33x2
CM-H-422	166	90	60	45	113	56	42x2
CM-H-482	185	112	70	56	126	63	48x2
CM-H-643	246	140	80	70	168	85	64x3
CM-H-803	246	140	80	70	168	95	80x3
CM-H-1003	345	200	100	100	250	112	100x3

Female clevis ISO 8133 (pivot pin included)

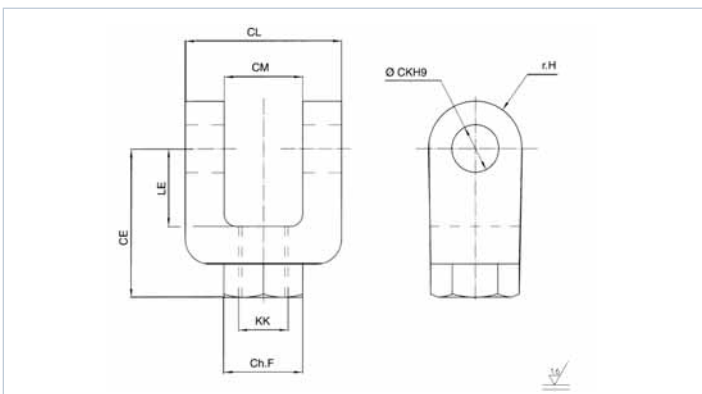

Part Number	CM	KK	CL	CE	LE	CK(h9)	Ch.F	r.H
260CF1310	12	M10x1,25	24	32	13	10	19	12
260CF1312	16	M12x1,25	32	36	19	12	21	17
260CF1314	20	M14x1,5	40	38	19	14	21	17
260CF1316	30	M16x1,5	60	54	32	20	32	29
260CF1320	30	M20x1,5	60	60	32	20	32	29
260CF1327	40	M27x2	80	75	39	28	40	34
260CF1333	50	M33x3	100	99	54	36	56	50
260CF1342	60	M42x2	120	113	57	45	56	53
260CF1348	70	M48x2	140	126	63	56	75	59
260CF1364	80	M64x3	160	168	83	70	95	78
260CF1380	80	M80x3	160	168	83	70	95	78

Spherical rod eye ISO 8133

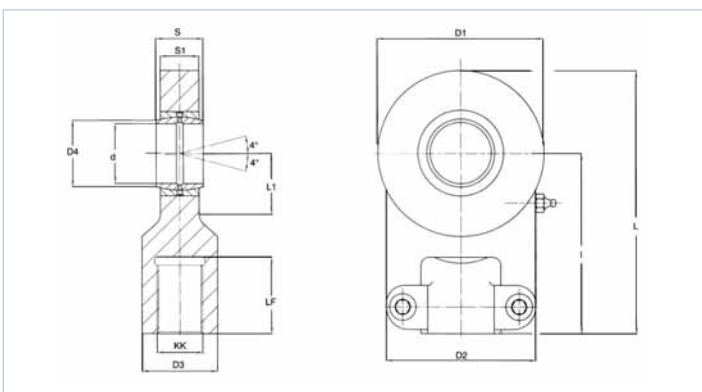

Part Number	d	S	D4	I	D1	D2	S1	L	L1	D3	LF	KK
290TAPR12S	12	10	15	42	35	40	8	58	16	17	15	M10x1,25
290TAPR16S	16	14	20,7	48	45	45	11	69	20	21	17	M12x1,25
290TAPR20S	20	16	24,1	58	55	55	13	83	28	25	19	M14x1,5
290TAPR25S	25	20	29,3	68	65	62	17	99	31	30	23	M16x1,5
290TAPR30S	30	22	34,2	85	80	77	19	123	35	36	29	M20x1,5
290TAPR40S	40	28	45	105	100	90	23	153	45	45	37	M27x2
290TAPR50S	50	35	56	130	120	105	30	188	58	55	46	M33x3
290TAPR60S	60	44	66,8	150	160	134	38	255	68	68	55	M42x2
290TAPR80S	80	55	89,4	185	205	156	47	282,5	82	90	64	M48x2
290TAPR100S	100	70	109,5	240	240	190	55	357,5	116	110	86	M64x3

SPECIAL APPLICATIONS

UMC manufacture a huge number of special hydraulic cylinders using non standard components aswell as ISO 6020/2 & DIN 24554. Specialist cylinders can be produced in numerous materials including cast iron and stainless steel. Please contact us for further information.

**BOAT INDUSTRY
HYDRAULIC TELESCOPIC GANGWAY**

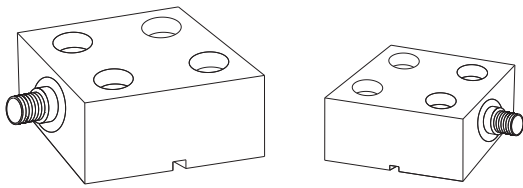
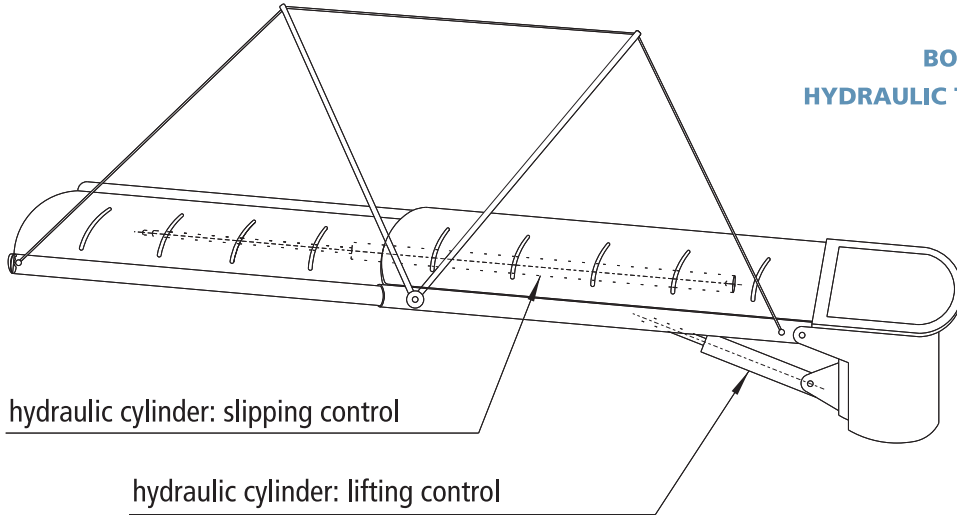

short stroke hydraulic cylinders

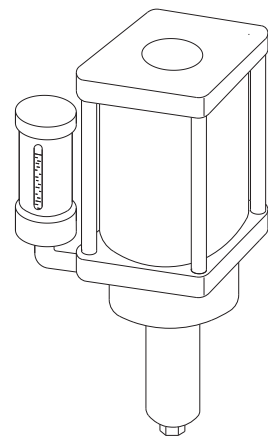

boosters air/water & air/oil

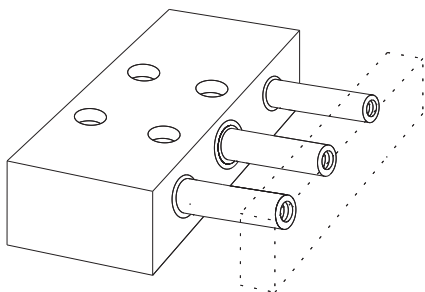

hydraulic cylinders with non-rotating device

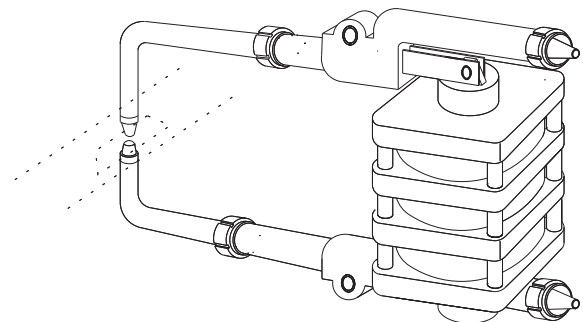

cylinders for manual spot welders

UNIVER Manufacturing Company LTD.

UK HEAD OFFICE

Station Road, Bradford,

West Yorkshire BD1 4SF

Tel: +44 (0) 1274 725777

Fax: +44 (0) 1274 725111

E-mail: enquiries@univer.co.uk

www.univer.co.uk



UNIVER MANUFACTURING COMPANY

UNIVER Manufacturing Company LTD.

UK Head Office

Station Road
Bradford
West Yorkshire BD1 4SF
Tel: +44 (0) 1274 725777
Fax: +44 (0) 1274 725111
E-mail: enquiries@univer.co.uk

LEADERS IN INDUSTRIAL AUTOMATION

www.univer.co.uk

